



UNIVERSITY OF CAMBRIDGE INTERNATIONAL EXAMINATIONS
General Certificate of Education
Advanced Subsidiary Level and Advanced Level

CANDIDATE
NAME

CENTRE
NUMBER

--	--	--	--	--

CANDIDATE
NUMBER

--	--	--	--

* 3 9 4 5 1 0 5 4 5 4 *

COMPUTING

9691/13

Paper 1

October/November 2012

1 hour 30 minutes

Candidates answer on the Question Paper.

No additional materials are required.

No calculators allowed.

READ THESE INSTRUCTIONS FIRST

Write your Centre number, candidate number and name on all the work you hand in.

Write in dark blue or black pen.

You may use a soft pencil for any diagrams, graphs or rough working.

Do not use staples, paper clips, highlighters, glue or correction fluid.

DO **NOT** WRITE IN ANY BARCODES.

Answer **all** questions.

No marks will be awarded for using brand names for software packages or hardware.

At the end of the examination, fasten all your work securely together.

The number of marks is given in brackets [] at the end of each question or part question.

This document consists of **13** printed pages and **3** blank pages.



1 (a) (i) Define what is meant by hardware.

.....
..... [1]

(ii) Define an output device and state why it is needed.

.....
.....
.....
.....
.....
..... [3]

The manager of a supermarket needs to send reports about sales of goods to head office.

(b) Explain how the following software can be used by the manager to produce and send the report:

(i) word processor

.....
..... [1]

(ii) spreadsheet

.....
..... [1]

(iii) communications software

.....
..... [1]

2 An expert system contains a Human Computer Interface (HCI).

Name **three** other parts of an expert system and state what each is used for.

Part 1

.....

.....

.....

Part 2

.....

.....

.....

Part 3

.....

.....

..... [6]

3 Two output formats are images and an interactive presentation.

State an application where each of these formats would be appropriate. Justify each of your choices.

(i) Images

Application

.....

Justification

..... [2]

(ii) Interactive presentation

Application

.....

Justification

..... [2]

- 4 A student has a home computer. She buys a new external hard disk to act as a back-up device for her system.

Describe the following examples of utility software and state how they would be used by the student.

(i) Hardware driver

Description

.....

.....

..... [2]

Use

..... [1]

(ii) Disk formatter

Description

.....

.....

..... [2]

Use

..... [1]

5 A systems analyst is employed to produce a new computer system to control a production line in a factory. One of the stages in the systems development life cycle is the feasibility study.

*For
Examiner's
Use*

Explain **five** reasons for carrying out a feasibility study.

1

.....

2

.....

3

.....

4

.....

5

..... [5]

6 (a) Describe the functions of the memory unit during the execution of a program.

.....
.....
.....
.....
.....
..... [3]

(b) State what is meant by:

(i) a buffer

.....
..... [1]

(ii) an interrupt

.....
..... [1]

(c) Describe how buffers and interrupts are used to control the transfer of data from the primary memory to a hard disk on a stand-alone computer system.

.....
.....
.....
.....
.....
.....
.....
.....
..... [4]

7 The details of the items on sale in a supermarket are stored as a sequential file with the barcode used as the key field.

(a) Describe what is meant by a sequential file in this case.

.....
.....
.....
..... [2]

(b) (i) The file is rearranged by adding a single level index based on the first digit of the barcode.

Explain how a record is found in this indexed sequential file. (You may use a diagram in your answer).

.....
.....
.....
.....
.....
.....

[3]

(ii) The file is rearranged using multi-level indexes.

Draw a diagram to show the structure of the file with the first two indexes.

*For
Examiner's
Use*

[2]

8 An interactive information system is being designed for use by the air-traffic controllers at an airport. Information about all planes must be available to the controllers who then ensure that the planes stay far enough apart not to be a danger to each other.

(a) (i) State an input device which would be suitable for use in this application. Justify your choice.

Device

Justification

..... [2]

(ii) State an output device which would be suitable for use in this application. Justify your choice.

Device

Justification

..... [2]

(b) Discuss the human computer interface (HCI) with reference to:

(i) the content

.....
.....
.....
.....
.....

(ii) the way the content is laid out

.....
.....
.....
.....
..... [5]

9 (a) Describe what is meant by the following types of data transmission:

(i) serial, full duplex transmission

.....
.....
.....
..... [2]

(ii) parallel, half duplex transmission

.....
.....
.....
..... [2]

(b) Define the term protocol.

.....
.....
.....
..... [2]

(c) When data is transmitted between devices it can be corrupted. One method to detect corruption is the use of a checksum.

Explain how a checksum can be used to detect the presence of errors in a transmission.

.....
.....
.....
.....
.....
.....
.....
.....
.....
..... [4]

10 (a) (i) Complete the truth table for this logic circuit.

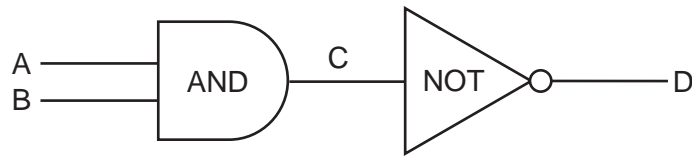

A	B	C	D
0	0		
0	1		
1	0		
1	1		

[1]

(ii) State a single logic gate which would have the same final outcome as this pair of logic gates.

..... [1]

For
Examiner's
Use

(b) Complete the truth table for this logic circuit.

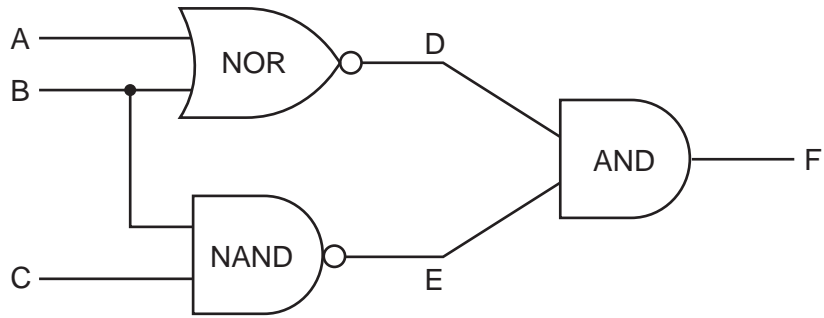

A	B	C	D	E	F
0	0	0			
0	0	1			
0	1	0			
0	1	1			

[4]

For
Examiner's
Use

BLANK PAGE

Permission to reproduce items where third-party owned material protected by copyright is included has been sought and cleared where possible. Every reasonable effort has been made by the publisher (UCLES) to trace copyright holders, but if any items requiring clearance have unwittingly been included, the publisher will be pleased to make amends at the earliest possible opportunity.

University of Cambridge International Examinations is part of the Cambridge Assessment Group. Cambridge Assessment is the brand name of University of Cambridge Local Examinations Syndicate (UCLES), which is itself a department of the University of Cambridge.